

BMK – Core Board Technical Specifications

BytePoster Master Kit (BMK) is a rapid prototyping kit developed for enterprises and researchers to realize Industrial IoT applications, Real Time Asset Monitoring solutions, Environmental Monitoring and other edge computing applications at a faster pace. BMK is a Microsoft Azure certified hardware platform which has an edge computing capability and communicates to cloud vendors in a secure communication using WiFi, BLE or LTE.

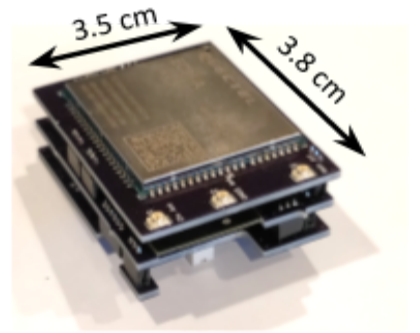

1. BytePoster Master Kit stack

Core Board:

Core Board mainly consists of

1. ESP - WROOM32
2. Voltage Regulation
3. Battery Management
4. SD Card support
5. Peripheral connectors

1. ESP – WROOM-32

BMK Core board is based on the ESP- WROOM32 module which has an ESP32-D0WDQ6 system on a chip (SoC) inside. This SoC contains an Xtensa dual core 32 bit LX6 microprocessor which is based on a Cadence IP, WiFi 802.11 & Bluetooth capability, 16MB Flash with a PCB antenna.

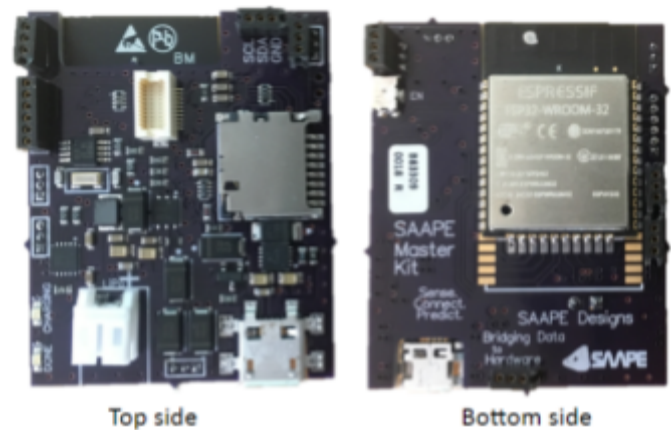

2. BMK - Core Board

More info:

ESP32-WROOM-32:

https://www.espressif.com/sites/default/files/documentation/esp32-wroom-32_datasheet_en.pdf

ESP32- D0WDQ6:

https://www.espressif.com/sites/default/files/documentation/esp32_datasheet_en.pdf

2. Voltage Regulation:

The voltage regulation circuit of the BMK-Core board consists of a

1. AP7176B

AP7176B is a 3.0A ultra low dropout linear regulator that features an enable input and power good output. The package used in the BMK-Core board is a U-DFN3030- 10 package. AP7176B regulator is configured to accept input voltage of 5V and convert into a regulated and stable 4.2V. The output current of this IC supports up to 3A.

2. LMR10510

LMR10510 is a DC/DC converter (buck regulator) which is responsible for a stable 3.0V power supply to the ESP32 module. The regulator on board is a DFN-6R/3x3x0.95 package.

Additionally voltage regulation consists of a dedicated power routing circuitry to isolate BMK-modem board voltage lines and the BMK- Core board voltage lines.

3. Battery Management:

Battery Management in the BMK Core board comprises of a DIO5158 chipset of DFN-10/3x3x0.5 package. DIO5158 is a complete constant- current/ constant voltage linear regulator for a single cell Li-ion and Li-polymer rechargeable batteries. The chip features capabilities like battery temperature monitoring, automatic low power sleep mode when the input voltage supply is removed and automatic recharge.

4. SD Card Support:

BMK Core board consists of a DM3D push-pull, manual without ejection mechanism SD Card slot. This enables the BMK core board to record all the external sensor data, device configurations, device performance logs.

5. Peripheral Connectors:

BMK Core board is designed such that external boards can be plugged into the core board and external digital sensor data in I2C lines can be captured. It supports a micro USB connector which can be used to power the board or a battery connector.

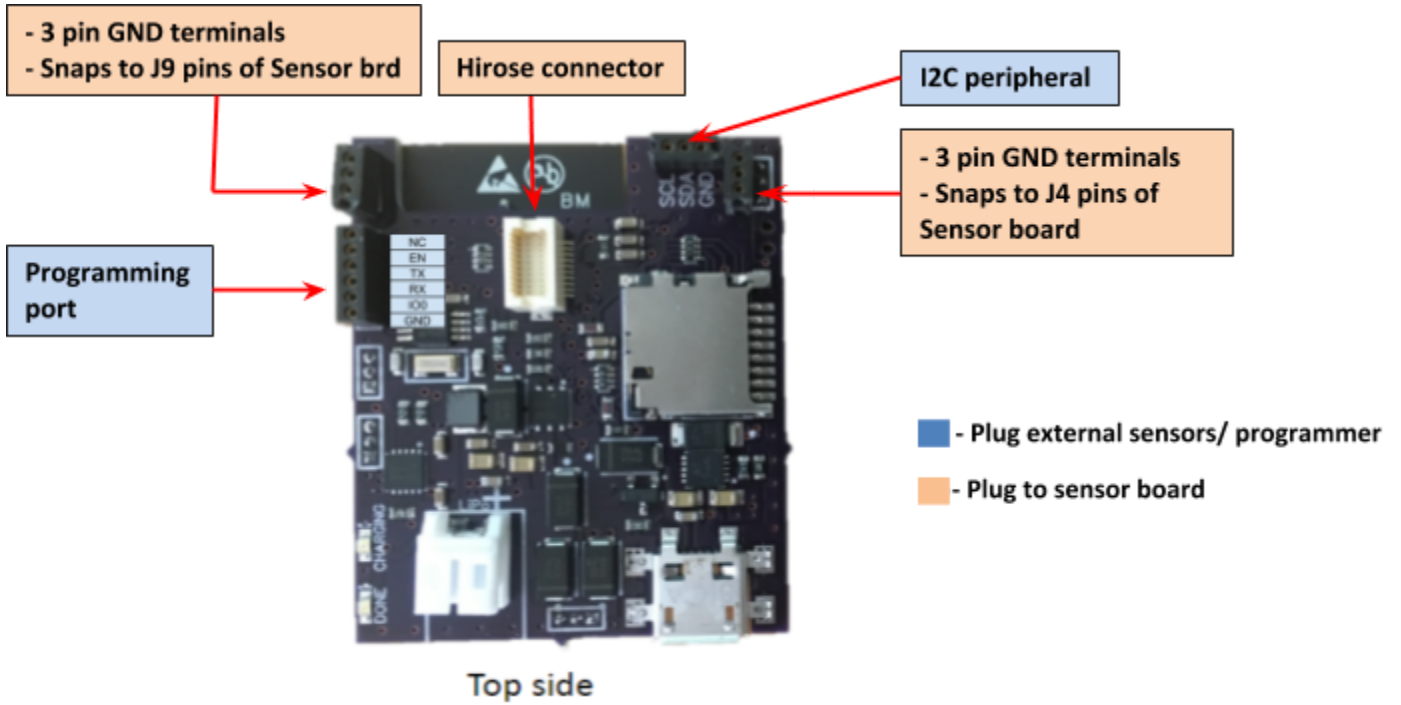

The above image shows the peripherals in the top side of the BMK- Core board. The connector in the image labeled in blue can be used to program the BMK-Core board or the be used to connect the external I2C sensors to the Core board. The connectors which are labeled in orange color should be plugged into the BMK-Sensor board. The Sensor board gets stacked on the top side of the BMK- Core board.

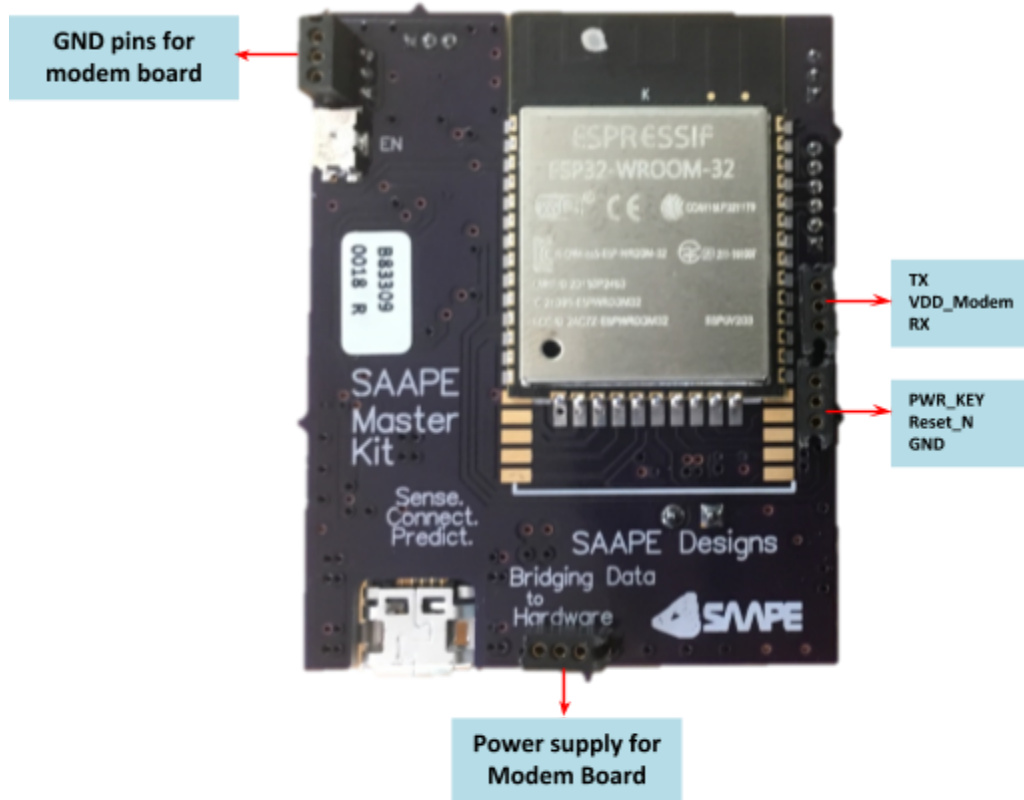

Bottom side of Core Board

The above image shows the peripherals in the bottom side of the BMK-core board. All connectors in the bottom side of the Core board gets plugged into the BMK-Modem board.

Revision:

Document:	BMK Core Board Technical Specifications
Version:	Version 1.1
Last updated Date:	4/21/2019